

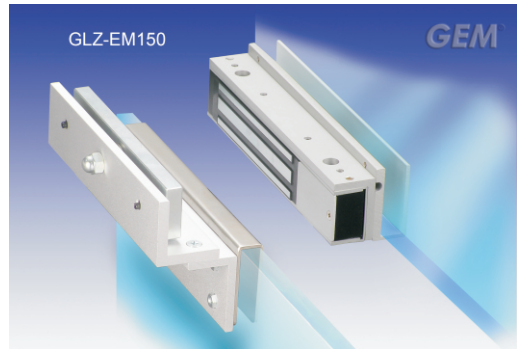

GLZ-EM150



With GLZ- bracket for in-swing frameless glass doors



(Maglock is not included)

■ Application of the Electromagnet: EM-150

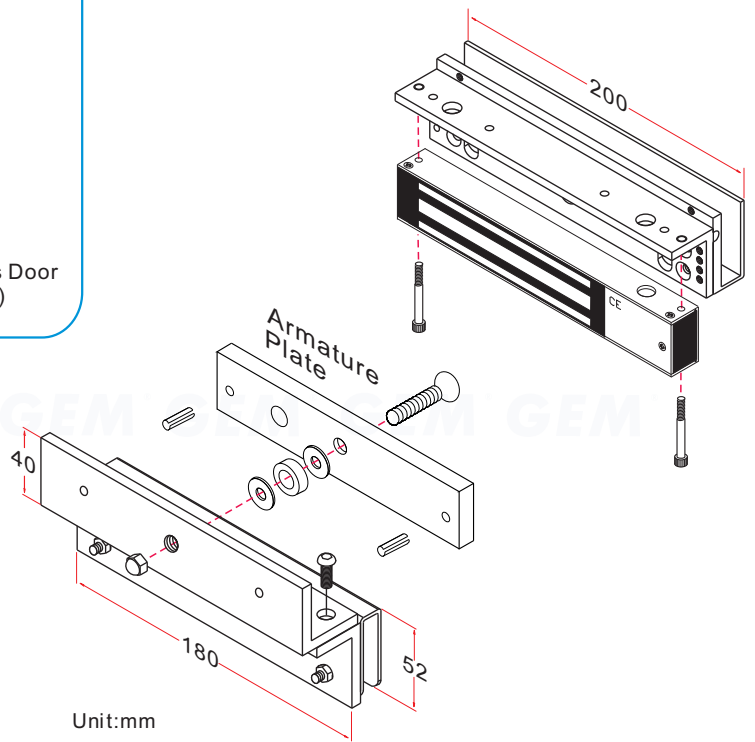
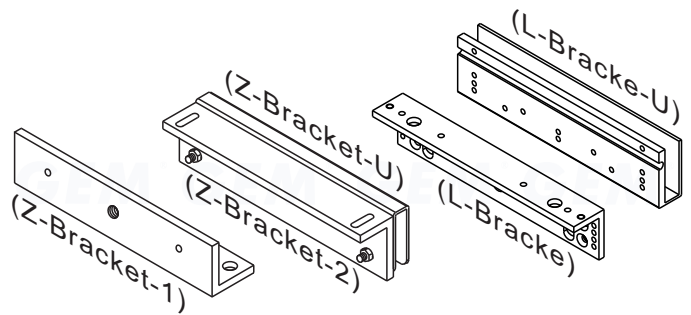
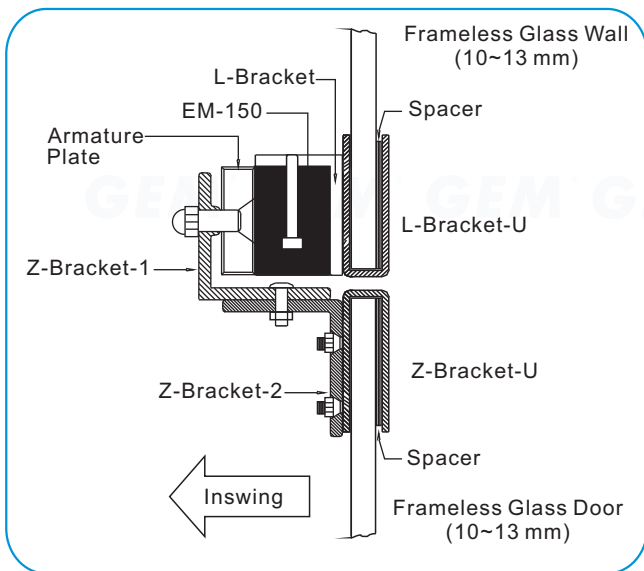

Unit:mm